



**CONNECT AND PROTECT**

# nVent ERICO Cadweld Plus for Rail

The Faster, Easier, and More Reliable Connection  
Worldwide Leader in Exothermic Connection Technology

  
nVent

**ERICO**



# nVent ERICO Cadweld Plus

## THE ULTIMATE WELDED CONNECTION THAT WILL NEVER LOOSEN, CORRODE OR INCREASE IN RESISTANCE

nVent is dedicated to continuous product improvement to meet its customers' needs and maintain the highest level of satisfaction. The introduction of Cadweld exothermic welded connections to the rail market in 1938 established nVent ERICO as the manufacturer of the ultimate connection for rail, a tradition that continues today around the world. Cadweld exothermic connections are also widely used for power, grounding, bonding, and cathodic protection applications.

Continuing the tradition of technical leadership, Cadweld Plus was developed to simplify the method of installing exothermically welded electrical connections on the rail and railway properties. This trusted system features an integrated welding material package which streamlines the installation process.

The integrated welding material package consists of a steel cup containing Cadweld F80 welding material alloys. The welding material package is designed for use in all standard Cadweld molds, including Cadweld Multi. Once placed in the Cadweld mold, the welding material is electronically ignited using a simple battery-powered control unit with a standard six-foot lead.

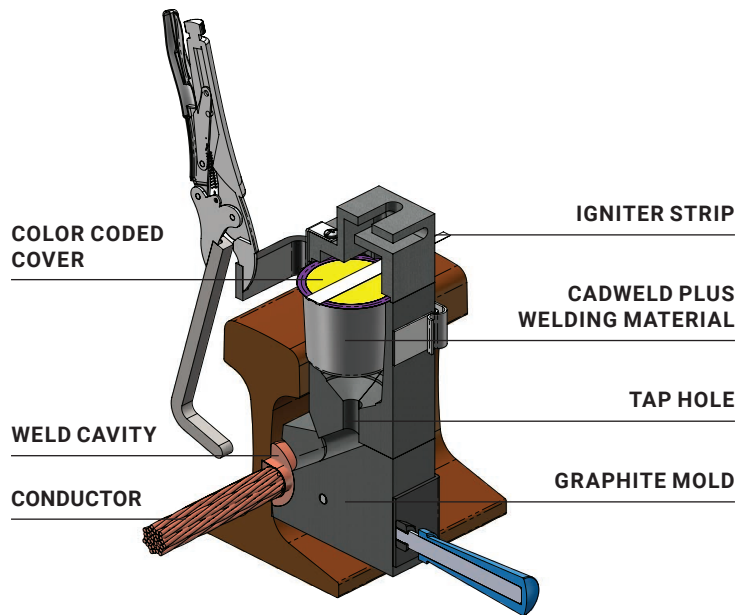

## CADWELD PLUS

Features	Benefits
Integrated Welding Material Package	<ul style="list-style-type: none"> <li>• Consistent welding material volume by size (no spillage when setting up connection)</li> <li>• Simplifies the installation process</li> <li>• Saves labor</li> </ul>
Color Coded Welding Material	<ul style="list-style-type: none"> <li>• Helps reduce risk of misapplication</li> <li>• Simplified training, set up and use</li> <li>• Simple visual verification of correct welding material size</li> </ul>
Electronic Control Unit	<ul style="list-style-type: none"> <li>• No starting material required</li> <li>• Easy ignition</li> </ul>
Replaceable Six or Fifteen Foot Control Unit Lead	<ul style="list-style-type: none"> <li>• Increased flexibility in hard to reach areas</li> </ul>



## CADWELD PLUS CONNECTIONS OFFER ALL THE BENEFITS OF CONVENTIONAL CADWELD CONNECTIONS:

- **Current carrying capacity** equal to or greater than that of the conductor.
- **Withstand repeated fault currents** without failing during operation.
- Permanent, molecular bond that **will not loosen or corrode**, resulting in a connection with a lifetime equal to that of the installation.
- Quality assurance **inspection is easy and visual**.
- **Minimal installation training** required.
- **Exceeds requirements of railroad and transit properties** around the world as well as AREMA and IEEE recommendations.



## THE CADWELD PLUS SYSTEM:

- Consists of a tamper proof, disposable, moisture-resistant welding material cup. The welding material, disk and ignition source are **incorporated into the self-contained package**.
- **Requires minimum components** – no starting material, no disks, no flint igniters.
- Cadweld Plus **F80 welding material is color coded with a yellow cover** and engineered for railway and railway property applications.
- The outer ring of the yellow **cover is color-coded by size** for ease of identification to prevent misapplication.
- Completes **welds at distances** of up to 6 ft/1.8 meters (up to 15 ft/4.6 meters with optional lead).
- **Easy to handle**, store and transport – by air, land or sea.
- PBPLUSCU control units have an electronic ignition with a CE/UL battery powered controller box that is **designed for a minimum of 400 connections** before needing new batteries.



## INSTALLATION IS EASY!

Proper rail surface preparation is paramount for any rail bond connection. Lightly grinding the rail surface, removing surface oxidation on the conductors, and drying and heating the rail and molds are highlighted in the instruction print. Once the preparation is completed, the four steps below complete the Cadweld Plus process.



# 1



Insert Cadweld Plus cup into mold.

# 2

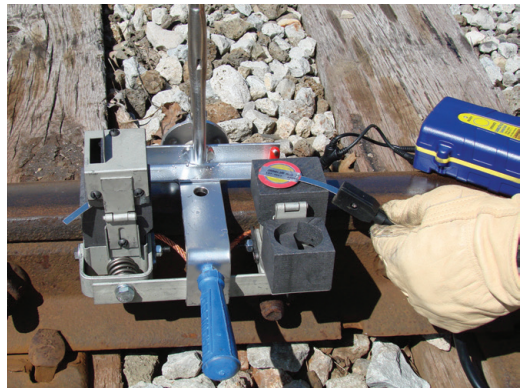

Attach control unit termination clip to ignition strip.

# 3



Press and hold control unit switch and wait for the ignition.

# 4



Open the mold and remove the expanded steel cup – no special disposal required.

# Our Product Offering

## INNOVATIVE SOLUTIONS SPECIFICALLY FOR HEAVY RAIL AND RAIL TRANSIT APPLICATIONS

### CADWELD PLUS CONTROL UNIT

#### Features:

- **Battery-powered controller box** designed for 400 connections with one set of batteries
- Requires **no special batteries or charger**
- Comes standard with **high temperature lead**
- Connects to the welding material ignition strip with a **custom made, purpose-designed termination clip**
- Sends a **predetermined voltage** to the ignition strip and initiates the reaction
- The PBPLUSCU control unit electronic ignitor is primarily designed for ignition of **Cadweld Plus Welding Material, F80**
- PBPLUSCU meets **AREMA® C&S Manual Recommendations**; Part 8.1.34, 2013



Part Number	PBPLUSCU	Standard PLUSCULDQC	Long PLUSCULD15QC
Type	Control Unit	Replacement Lead Only	Replacement Leads Only
Cable Length	6 ft/1.8 meters	6 ft/1.8 meters	15 feet/4.6 meters
Batteries	8 Lithium AA Batteries		
Working Temperature	-40°F to 140°F / -40°C to 60°C		
Certifications	cURus		
Standard Packaging Quantity	1 Each	1 Each	1 Each
UPC	78285690849	78285661900	78285661902

### CADWELD PLUS WELDING MATERIAL, F80

#### FEATURES:

- Mixture consists mainly of copper oxide and aluminum
- Primarily used alloy in making connections to load-bearing rail
- Integrated welding material package
- Color coding by size for easy identification
- Electronic ignition
- No starting material required
- Non-explosive
- See specific Cadweld connection details to determine welding material requirements



Part Number	Color Code Ring	Standard Package Quantity
SB25PLUSF80	Red	20 pc
SB32PLUSF80	White	20 pc
PB45PLUSF80	Light Blue	20 pc
PB65PLUSF80	Dark Green	20 pc
PB90PLUSF80	Gray	10 pc
PB115PLUSF80	Orange	10 pc
PB150PLUSF80	Dark Blue	10 pc
PB200PLUSF80	Yellow	10 pc
PB250PLUSF80	Purple	10 pc
PB300PLUSF80	Light Green	10 pc
PB400PLUSF80	Brown	10 pc
PB500PLUSF80	Light Brown	10 pc





Our powerful portfolio of brands:

**CADDY ERICO HOFFMAN RAYCHEM SCHROFF TRACER**



[nVent.com/ERICO](https://www.nVent.com/ERICO)

**WARNING:** nVent Engineered Electrical & Fastening Solutions is a leading global manufacturer and marketer of superior engineered products for niche electrical, mechanical and concrete applications. These nVent products are sold globally under a variety of market-leading brands: ERICO welded electrical connections, facility electrical protection, and rail and industrial products; CADDY fixing, fastening and support products; ERIFLEX low-voltage power and grounding connections; and LENTON engineered systems for concrete reinforcement.

©2018 nVent. All nVent marks and logos are owned or licensed by nVent Services GmbH or its affiliates. All other trademarks are the property of their respective owners. nVent reserves the right to change specifications without notice.

ERICO-SB-R334LT16WWEN-Cadweldplusforrail-EN-1805